

Axial-Werkzeughalter Form C2 links

Axial toolholders form C2 left

Porte-outils axials forme C2 gauche

DIN ISO 10889-1
(DIN 69880)



Verwendung:
Vorwiegend für Außenbearbeitung.
Zum Plan Einstecken.

Application:
Mainly for external machining.
For face machining.

Application:
Principalement pour usinage extérieur.
Pour carottage.

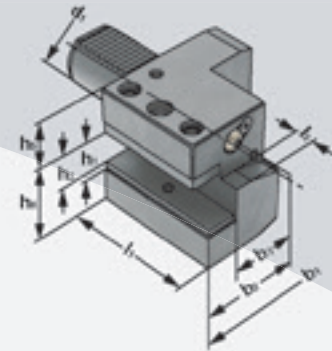

DIN ISO 10889
(DIN 69880)

C2

Bestell-Nr. Order no. Référence	Abmessung Size Dimension	d ₁	h ₁	h ₂	b ₁	b ₂	b ₃	l ₁	l ₂	h ₅	h ₆
169.42.12	C2 – 16 × 12	16	12	–	43	24	13	44	5	20	22
209.42.16	C2 – 20 × 16	20	16	12	65	40	26	50	–	25	30
259.42.16	C2 – 25 × 16	25	16	12	58	33	26	55	7	20	30
309.42.20	C2 – 30 × 20	30	20	16	76	41	23	70	10	28	38
409.42.25	C2 – 40 × 25	40	25	20	90	47,5	25,5	85	12,5	32,5	48
509.42.32	C2 – 50 × 32	50	32	25	105	55	30,5	100	16	35	60

Ausführung: Mit einstellbarer Kugelspritzdüse und Unterlegplatte
Version: *With adjustable spray nozzle and shim*
Version: Avec gicleur ajustable et semelle

